



ASKOHEAT-OP

Einschraubheizkörper R 1½“ für Trink- und Heizungswasser
Geeignet für Verbrauchsregler Fronius Ohmpilot



AHIR-BI-OP-1.0 bis 9.0 kW

- AHIR-BI-OP-1.0 / 012-5501
- AHIR-BI-OP-2.0 / 012-5502
- AHIR-BI-OP-2.5 / 012-5503
- AHIR-BI-OP-3.0 / 012-5504
- AHIR-BI-OP-3.8 / 012-5505
- AHIR-BI-OP-4.5 / 012-5506
- AHIR-BI-OP-6.0 / 012-5507
- AHIR-BI-OP-7.5 / 012-5508*
- AHIR-BI-OP-9.0 / 012-5509*

ASKOMA *we care
about energy*

DATENBLÄTTER

• Deutsch	Seite	2 - 4
• English	Page	5 - 7
• Français	Page	8 - 10
• Italiano	Pagina	11 - 13
• Español	Página	14 - 16

Typ OP

Einschraub-Heizkörper Isolierte Montage

AHIR-BI-OP-...

mit Temperaturregler / -begrenzer Kombination
für Verbrauchsregler Fronius Ohmpilot



PV-Eigenstromverbrauch

- Heizstäbe für stufenlose Ansteuerung mit:
 - Fronius Ohmpilot bis 9 kW
 - AC•THOR (my PV)
 - o AC•THOR bis max. 3 kW
 - o AC•THOR 9s bis max. 9 kW
 - SolarEdge Home Warmwasser-Controller bis max. 3 kW
- Regelung der Leistung von 0 bis 100%



Anwendung

Als Zusatzheizung von Trink- und Heizungswasser in Photovoltaikanlagen. Der Einsatz in Wasser-Glykol-Gemisch oder anderen Medien, wird mit diesen Heizelementen nicht unterstützt.

Jedoch kann Ihnen Askoma AG andere Heizelemente dafür anbieten.

Merkmale

EHK Der Heizkörper besteht aus drei U-förmigen Rundheizstäben, die in einem Messingnippel 1/2" konisch mittels lebensmittelechten Kunststoffhülsen isoliert montiert sind. Dank dem isolierten Einbau der Rundheizstäbe sind die Geräte auch für emaillierte Speicher geeignet. Mittels integriertem DIP-Schalter ist der Potentialausgleichswiderstand für die Nutzung in Edelstahlspeicher überbrückbar. Die unbeheizte Zone beträgt bei allen Leistungen 150 mm. Für die tägliche Erhitzung des Warmwassers geeignet.

TR Elektromechanischer Temperaturregler nach EN 14597, nicht bruchsicher.

STB Elektromechanischer Temperaturbegrenzer nach EN 14597, bruchsicher, bei Überschreiten der Ausschalttemperatur schaltet das Schaltwerk AUS und bleibt in dieser Stellung verriegelt. Entriegeln erfolgt manuell nach Abkühlung des Fühlrohrs um ca. 10 K.

- Zeitkonstante des Fühlrohrs nach EN 14597
- Wirkungsweise TR Typ 2 B nach EN 14597
- Wirkungsweise STB Typ 2 BK nach EN 14597

Typenübersicht

Trink- und Heizungswasser
Incoloy 825, 2.4858

Typ	Bestell-Nr.	Leistung	Eintauchlänge [EL]
AHIR-BI-OP-1.0	012-5501	1.00 kW; 230V~ / 400V 3~	300mm
AHIR-BI-OP-2.0	012-5502	2.00 kW; 230V~ / 400V 3~	300mm
AHIR-BI-OP-2.5	012-5503	2.50 kW; 230V~ / 400V 3~	350mm
AHIR-BI-OP-3.0	012-5504	3.00 kW; 230V~ / 400V 3~	400mm
AHIR-BI-OP-3.8	012-5505	3.80 kW; 400V 3~	450mm
AHIR-BI-OP-4.5	012-5506	4.50 kW; 400V 3~	500mm
AHIR-BI-OP-6.0	012-5507	6.00 kW; 400V 3~	600mm
AHIR-BI-OP-7.5*	012-5508*	7.50 kW; 400V 3~	700mm
AHIR-BI-OP-9.0*	012-5509*	9.00 kW; 400V 3~	750mm

Technische Daten

Die folgenden Angaben gelten für die oben aufgelisteten Normaltypen. Hiervon abweichende Varianten haben funktionsbedingt andere Daten.

Anwendungsbereich	Einstellbereich	0...*...28...85 °C
	Ausschalttemperatur ϑ_{off}	110 °C (0-9 K)
	Umgebungstemperatur am Schaltwerk	max. 50 °C (T50)
	Thermische Schaltdifferenz	11.0 K \pm 5.5 K
	Umgebungstemperatur bei Lagerung und Transport	-30...+90 °C
Eichung	Eichtoleranz	\pm 7 K
Ausführung	Zeitkonstante in Wasser	<45 s
	Anschlussgewinde	R 1½ " konisch
	Pressmessingnippel	CuZn40Pb2
	Rundheizstab	Incoloy 825, 2.4858
	Oberflächenbelastung	8-9 W/cm ²
	Elektrischer Anschluss	Schraubtechnik
	Betriebsdruck	max. 10 bar
	Gehäuseoberteil	Polycarbonate, RAL 7035 (lichtgrau)
Gehäuseunterteil	Polycarbonat, RAL 7016 (anthrazitgrau)	
Schutzart	IP41 nach EN 60529	

Montagehinweis

Der Einbau muss waagrecht erfolgen. Die Rundheizstäbe müssen völlig mit Flüssigkeit bedeckt sein. Der Flüssigkeitsumlauf durch die Heizkörper darf nicht behindert werden.

Bitte beachten: Dieser Heizstab ist sowohl für Edelstahl-Speicher, als auch für Schwarzstahl- / emaillierte Speicher einsetzbar. Je nach Speichertyp muss die Einstellung per DIP-Schalter im Gehäuseinneren gewählt werden.

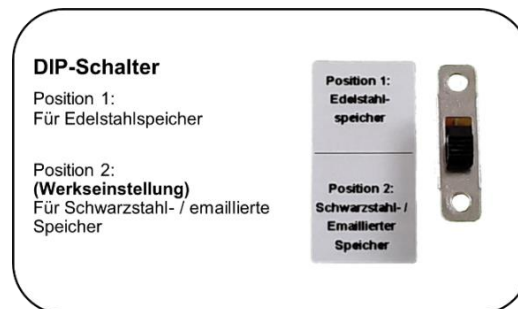

Schaltschema

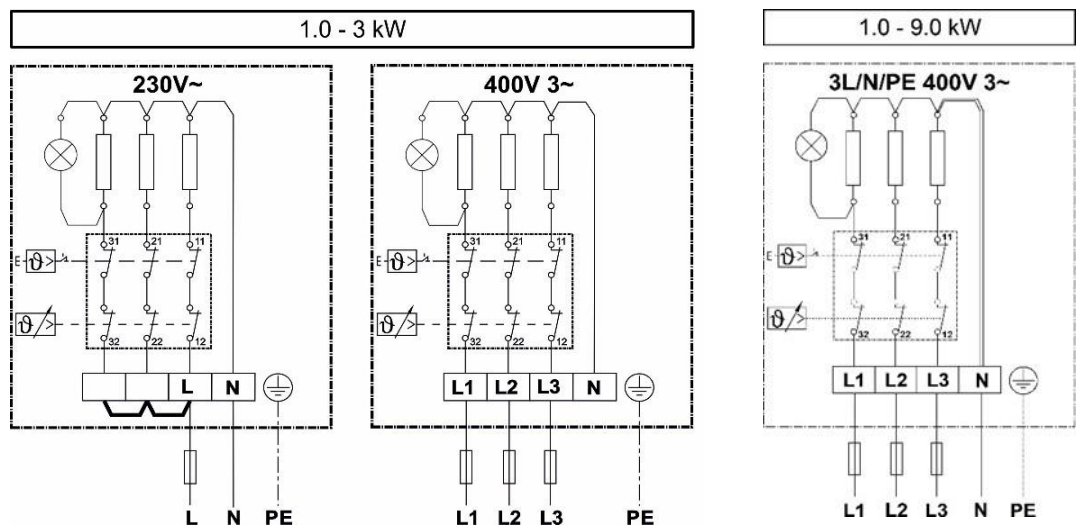

Massbild
012-5501- 012-5507

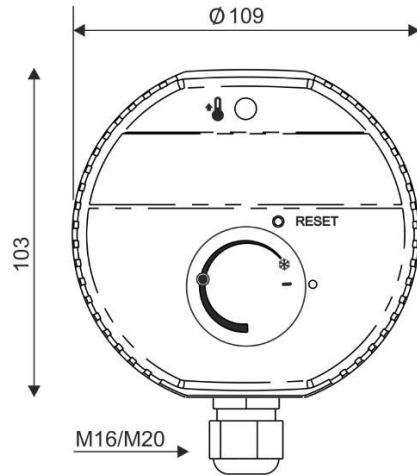
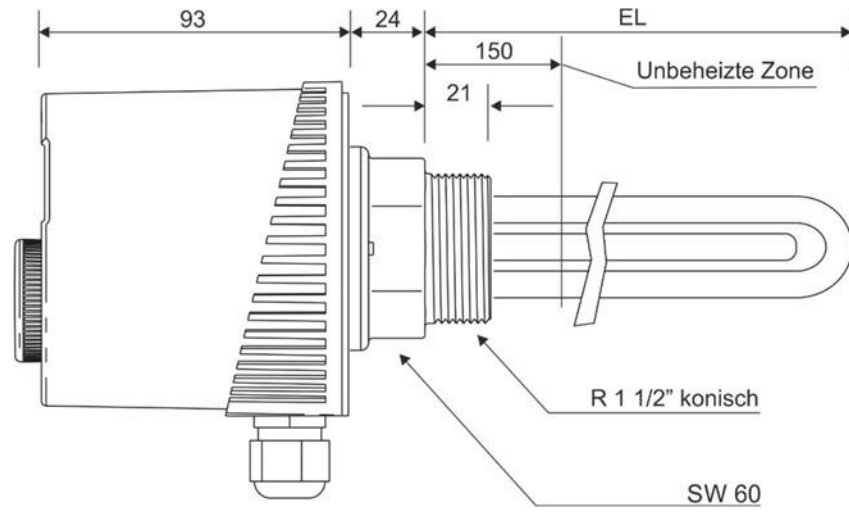

Massbild
012-5508 – 012-5509

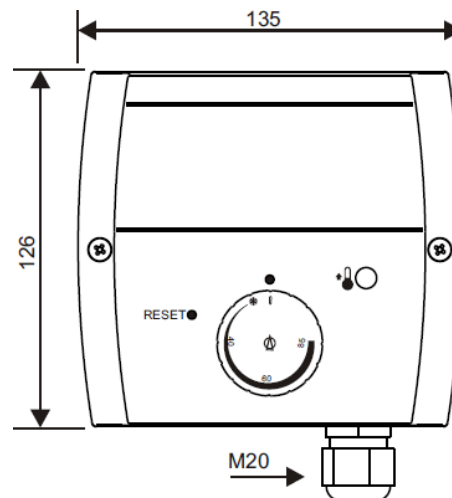
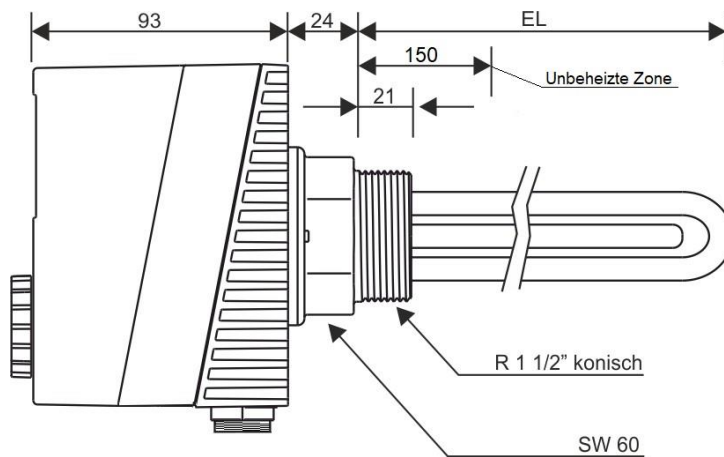

Screw-in heater insulated mounting

AHIR-BI-OP-...

With combination of temperature control and safety
temperature limiter
Compatible with the consumption regulator
Fronius Ohmpilot



PV own power consumption

- Heating elements for stepless control with:
 - Fronius Ohmpilot up to 9 kW
 - AC•THOR (my PV)
 - o AC•THOR up to max.3 kW
 - o AC•THOR 9s up to max. 9 kW
 - SolarEdge Home hot water controller up to max. 3 kW
- Power regulation from 0 to 100%



Application

Auxiliary heating system of drinking water and heating water in photovoltaic systems. These heating elements are not suitable for use in water-glycol mixtures or other media. However, Askoma AG can offer you other heating elements for this purpose.

Features

- SH The heating element is made of three U-shaped heating tubes, which are mounted isolated into a 1½" conical brass nipple by food-safe plastic sleeves. Thanks to the insulated mounting of the heating tubes, the devices are also suitable for enamelled boilers. By using the integrated DIP switch, the potential equalisation resistance for the usage in stainless steel tanks is bridgeable. The unheated zone is 150 mm for all types. Suitable for daily heating of hot water.
- TC Electromechanical temperature control acc. EN 14597, not fail safe.
- STL Electromechanical safety temperature limiter acc. EN 14597, fail safe. If nominal value is reached, the limiter switches and stays locked in this position. Reset is performed manually and is only possible after the sensing element is cooled off by approx. 10 K.
- Time factor of sensing element acc. EN 14597
 - Operation type TC Type 2 B acc. EN 14597
 - Operation type STL Type 2 BK acc. EN 14597

Type summary

Drinking- and heating water
Incoloy 825, 2.4858

Type	Order no.	Power	Immersion length [EL]
AHIR-BI-OP-1.0	012-5501	1.00 kW; 230V~ / 400V 3~	300mm
AHIR-BI-OP-2.0	012-5502	2.00 kW; 230V~ / 400V 3~	300mm
AHIR-BI-OP-2.5	012-5503	2.50 kW; 230V~ / 400V 3~	350mm
AHIR-BI-OP-3.0	012-5504	3.00 kW; 230V~ / 400V 3~	400mm
AHIR-BI-OP-3.8	012-5505	3.80 kW; 400V 3~	450mm
AHIR-BI-OP-4.5	012-5506	4.50 kW; 400V 3~	500mm
AHIR-BI-OP-6.0	012-5507	6.00 kW; 400V 3~	600mm
AHIR-BI-OP-7.5*	012-5508*	7.50 kW; 400V 3~	700mm
AHIR-BI-OP-9.0*	012-5509*	9.00 kW; 400V 3~	750mm

Technical data

Application range

The following indications are valid for the above listed standard types. Due to the function, other types might show different data.

Adjustable cut-off temperature 0...*...28...85 °C
 Safety cut-off temperature ϑ_{off} 110 °C (0-9 K)
 Ambient temperature on switching head max. 50 °C (T50)
 Thermal switching differential 11.0 K \pm 5.5 K
 Ambient temperature for storage and transport -30...+90 °C

Calibration

Calibration tolerance \pm 7 K
 Time factor in water <45 s

Specification

Fitting thread R 1½ " conical
 Brass nipple CuZn40Pb2
 Heating tube Incoloy 825, 2.4858
 Surface load 8-9 W/cm²
 Electrical connection Screw clip
 Operating pressure max. 10 bar
 Housing cover Polycarbonate, RAL 7035 (light gray)
 Housing base Polycarbonate, RAL 7016 (anthracite grey)
 Protection mode IP41 acc. EN 60529

Fitting notes

The device must be installed horizontally. The heating tubes must be covered entirely by the liquid. The circulation of the liquid shall not be inhibited.

Please note: This heating element is applicable in stainless steel boilers as well as in black steel / enamelled boilers. Select the settings via DIP switch in the housing interior according to the boiler type.

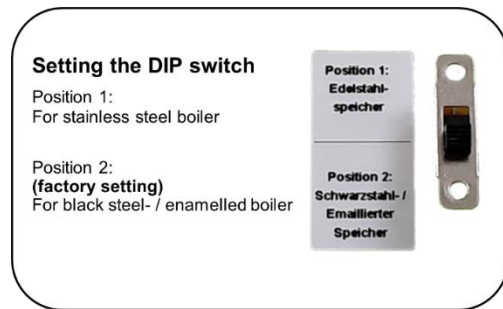

Wiring diagram

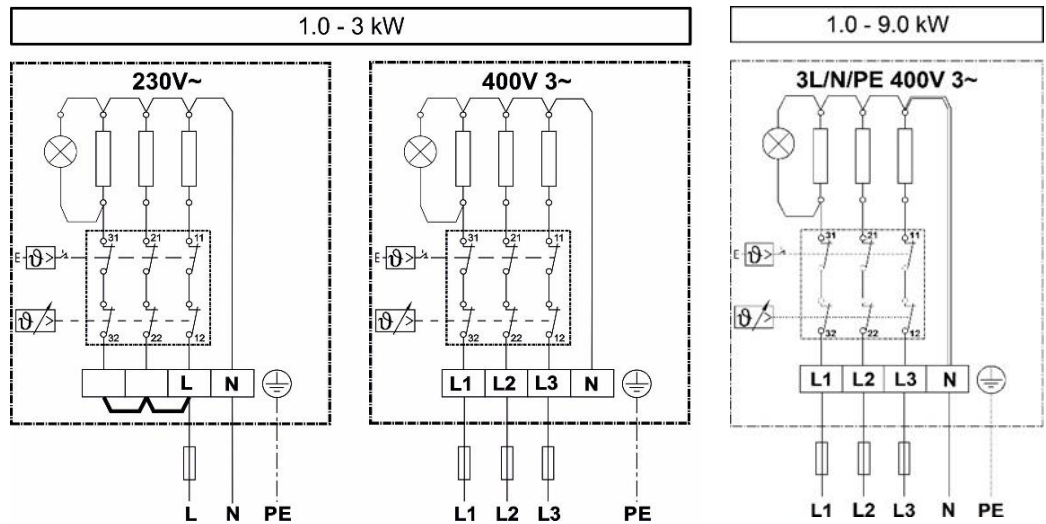

**Dimension drawing
012-5501 – 012-5507**

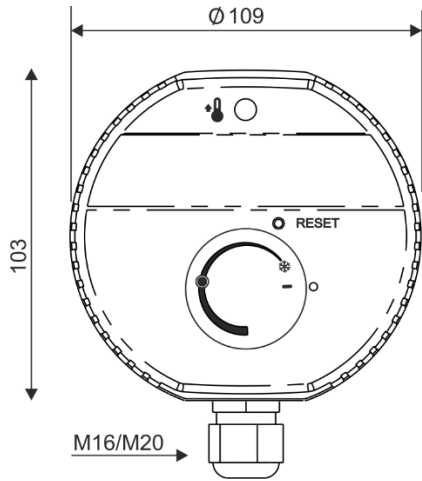
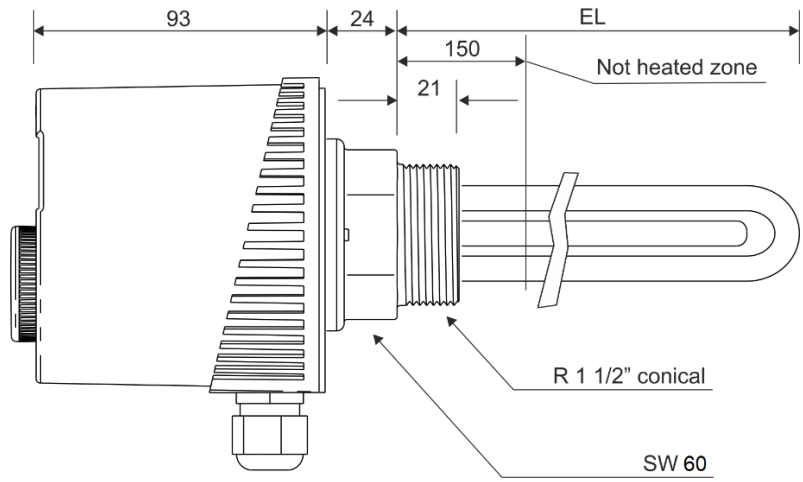

**Dimension drawing
012-5508 – 012-5509**

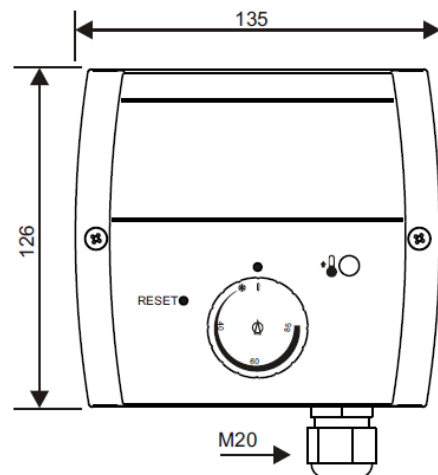
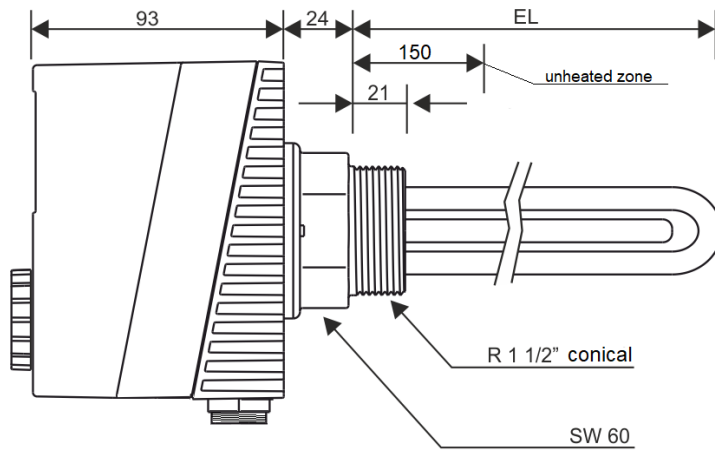

Type OP

Corps de chauffe à visser Montage isolé

AHIR-BI-OP-...

avec la combinaison régulateur / limiteur de température
pour le contrôleur de la consommation
Fronius Ohmpilot



Votre propre consommation d'énergie PV

- Élément chauffants avec contrôle continue via:
 - Fronius Ohmpilot jusqu' à 9 kW
 - AC•THOR (my PV)
 - o AC•THOR jusqu'à max. 3 kW
 - o AC•THOR 9s jusqu'à max. 9 kW
 - SolarEdge Home contrôleur d'eau chaude jusqu'à max. 3 kW
- Régulation des performances de 0 à 100%



Utilisation

Comme chauffage supplémentaire pour l'eau potable et l'eau de chauffage dans les systèmes photovoltaïques.

L'utilisation dans un mélange eau-glycol ou d'autres fluides n'est pas prise en charge par ces éléments chauffants.

Pendant, Askoma AG peut vous proposer d'autres éléments chauffants à cet effet.

Caractéristiques

CCV Le corps de chauffe se compose de trois tubes de chauffe en forme U, qui sont montés dans un raccord en laiton conique de 1 1/2" isolé par des manchons en plastique de qualité alimentaire. Grâce à l'installation isolée des éléments chauffants rond, les unités conviennent également au réservoir émaillé. La résistance d'équilibrage de potentiel peut être contournée au moyen d'un interrupteur DIP Switch intégré pour l'utilisation dans des réservoirs en acier inoxydable.

La zone non chauffée est de 150 mm pour chaque type de puissance
Convient pour le chauffage quotidien de l'eau chaude.

TR Thermostat de régulation électromécanique selon la norme EN 14597, non résistant à la rupture.

LS Limiteur de sécurité électromécanique selon la norme EN 14597, résistant à la rupture, dès que la température de déconnexion est dépassée, le mécanisme de commutation commute sur HORS tension et reste verrouillé dans cette position. Le déverrouillage est exécuté manuellement après que le tube de remplissage se soit refroidi d'environ 10 K.

- Constante de temps du tube de remplissage selon la norme EN 14597
- Mode d'action TR Typ 2 B selon la norme EN 14597
- Mode d'action LS Typ 2 BK selon la norme EN 14597

Aperçu de type

Eau potable et
Eau de chauffage
Incoloy 825, 2.4858

Type	No. de commande	Puissance	Longueur d'immersion [EL]
AHIR-BI-OP-1.0	012-5501	1.00 kW; 230V~ / 400V 3~	300mm
AHIR-BI-OP-2.0	012-5502	2.00 kW; 230V~ / 400V 3~	300mm
AHIR-BI-OP-2.5	012-5503	2.50 kW; 230V~ / 400V 3~	350mm
AHIR-BI-OP-3.0	012-5504	3.00 kW; 230V~ / 400V 3~	400mm
AHIR-BI-OP-3.8	012-5505	3.80 kW; 400V 3~	450mm
AHIR-BI-OP-4.5	012-5506	4.50 kW; 400V 3~	500mm
AHIR-BI-OP-6.0	012-5507	6.00 kW; 400V 3~	600mm
AHIR-BI-OP-7.5*	012-5508*	7.50 kW; 400V 3~	700mm
AHIR-BI-OP-9.0*	012-5509*	9.00 kW; 400V 3~	750mm

Données techniques

Domaine d'utilisation

Les indications suivantes sont valables pour les types normaux listés ci-dessus. Les modèles qui en varient ont d'autres données, en raison de leur fonctionnement.

Plage de réglage 0...*...28...95 °C
 Température de déconnexion ϑ_{off} 110 °C (0-9 K)
 Température ambiante sur le mécanisme de commutation max. 50 °C (T50)
 Différence de commutation thermique 11.0 K \pm 5.5 K
 Température ambiante lors du stockage et du transport -30...+90 °C

Etalonnage

Tolérance d'étalonnage \pm 7 K
 Constante de temps dans l'eau <45 s

Spécifications

Filetage de raccordement R 1½" conique
 Raccord fileté en laiton CuZn40Pb2
 Tube eau Incoloy 825, 2.4858
 Sollicitation surfacique 8-9 W/cm²
 Raccordement électrique Borne à vis
 Pression service max. 10 bar
 Couvercle de boîtier Polycarbonat, RAL 7035 (gris clair)
 Fond de boîtier Polycarbonat, RAL 7016 (gris anthracite)
 Type de protection IP41 selon la norme EN 60529

Indication de montage

Le montage doit être réalisé à l'horizontale. Les tubes de chauffe doivent être entièrement recouverts de liquide. Les corps de chauffe ne doivent pas entraver la circulation du liquide.

Veuillez noter que le corps de chauffe est utilisable aussi bien pour les réservoirs en acier inoxydable ainsi que pour les réservoirs en acier noir / acier noir émaillé. Choisissez les paramètres par interrupteur DIP Switch selon le type du réservoir.

Régler l'interrupteur DIP

Position 1:
Pour les réservoirs en acier inoxydable

Position 2:
(Réglage d'usine)
Pour les réservoirs en acier noir / acier noir émaillé



Schéma de câblage



Plan coté
012-5501- 012-5507

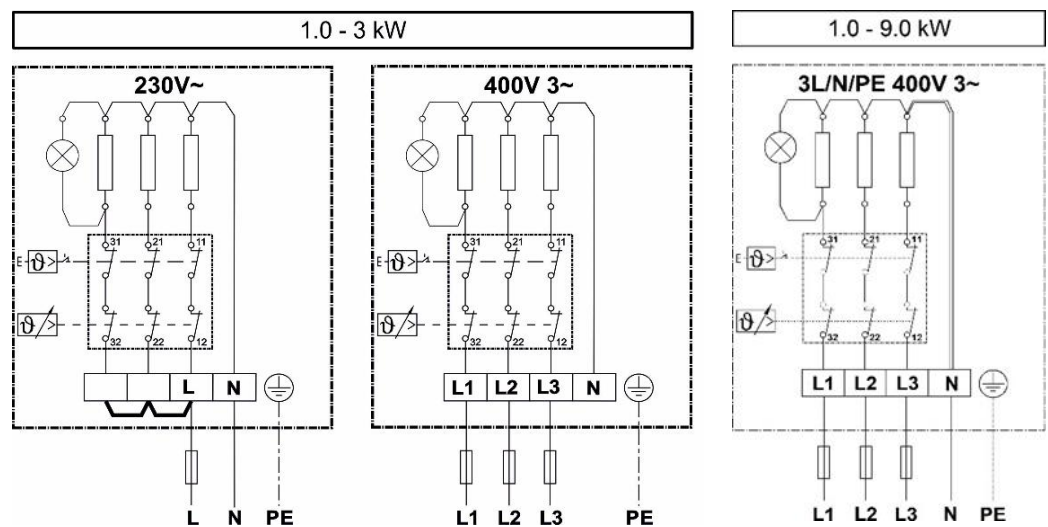
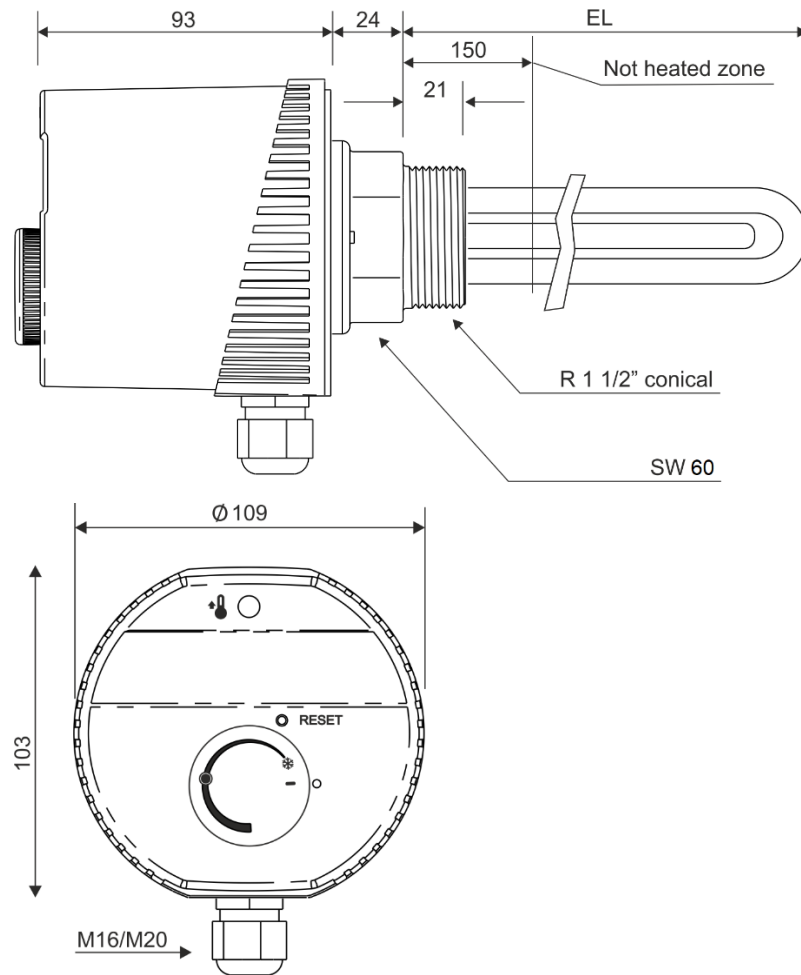

Plan coté
012-5508- 012-5509

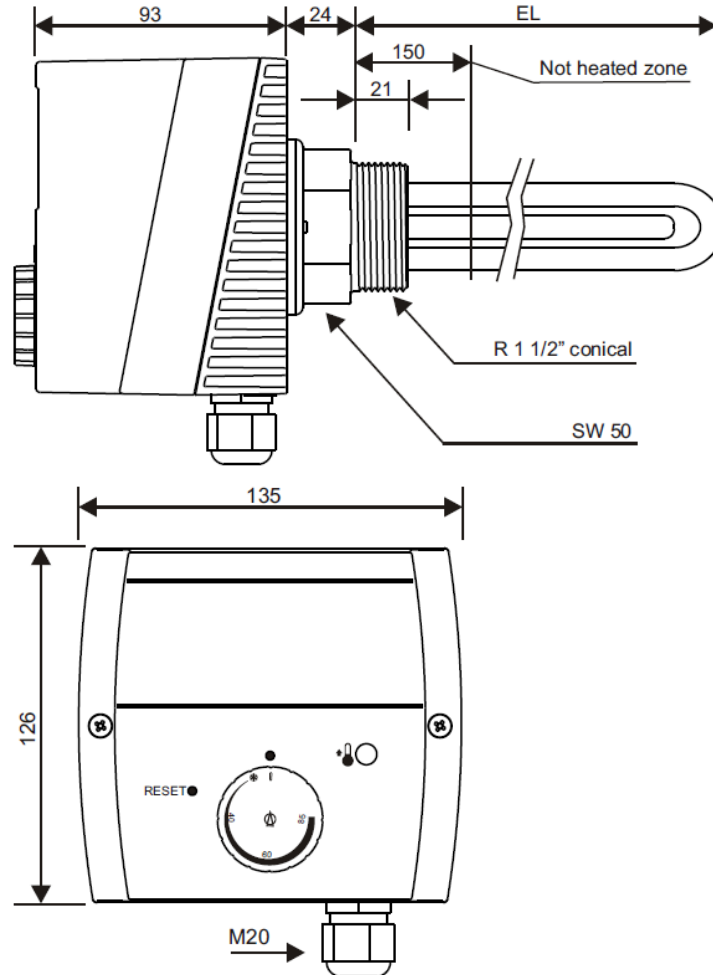

Tipo OP

Resistenza elettrica con
montaggio isolato

AHIR-BI-OP-...

con combinazione di termoregolatore / limitatore per
regolatore di consumo Fronius Ohmpilot**Autoconsumo fotovoltaico**

- Aste riscaldanti per la regolazione continua con:
 - Fronius Ohmpilot fino a 9 kW
 - AC•THOR (my PV)
 - o AC•THOR fino a max. 3 kW
 - o AC•THOR 9s fino a max. 9 kW
 - SolarEdge Home regolatore die acqua fino a max. 3 kW
- Regolazione della potenza da 0 a 100%

**Applicazione**

Come riscaldamento aggiuntivo per acqua potabile e di riscaldamento negli impianti FV. L'uso con miscele acqua-glicole o altri fluidi non è supportato da queste resistenze. Tuttavia, Askoma AG è in grado di offrirvi altre resistenze adatte a questo scopo.

Caratteristiche

RE La resistenza elettrica è costituita da tre aste riscaldanti rotonde a forma di U, montati in un raccordo in ottone da 1½" isolato con dei manicotti di plastica per alimenti. Grazie al montaggio isolato degli elementi riscaldanti rotondi, i dispositivi sono adatti anche per serbatoi smaltati. A seconda del tipo di serbatoio, selezionare le impostazioni tramite interruttore DIP integrato.

La zona non riscaldata ammonta per tutte le potenze a 150 mm.
Adatto per il riscaldamento quotidiano dell'acqua calda.

RT Regolatore di temperatura elettromeccanico, secondo EN 14597, non infragibile.

LST Limitatore di temperatura elettromeccanico, secondo EN 14597, infragibile, se viene superata la temperatura massima di spegnimento, il meccanismo di commutazione si spegne e rimane bloccato in quella posizione. Lo sblocco viene eseguito manualmente dopo che il tubo del sensore si è raffreddato di circa 10 K.

- Costante di tempo del sensore secondo EN 14597
- Modalità di azione RT Tipo 2 B secondo EN 14597
- Modalità di azione LST Tipo 2 BK secondo EN 14597

Presentazione tipi

Acqua potabile e di
riscaldamento
Incoloy 825, 2.4858

Tipo	No. Ordine	Potenza	Lunghezza immersione [L]
AHIR-BI-OP-1.0	012-5501	1.00 kW; 230V~ / 400V 3~	300mm
AHIR-BI-OP-2.0	012-5502	2.00 kW; 230V~ / 400V 3~	300mm
AHIR-BI-OP-2.5	012-5503	2.50 kW; 230V~ / 400V 3~	350mm
AHIR-BI-OP-3.0	012-5504	3.00 kW; 230V~ / 400V 3~	400mm
AHIR-BI-OP-3.8	012-5505	3.80 kW; 400V 3~	450mm
AHIR-BI-OP-4.5	012-5506	4.50 kW; 400V 3~	500mm
AHIR-BI-OP-6.0	012-5507	6.00 kW; 400V 3~	600mm
AHIR-BI-OP-7.5*	012-5508*	7.50 kW; 400V 3~	700mm
AHIR-BI-OP-9.0*	012-5509*	9.00 kW; 400V 3~	750mm

Dati tecnici

Le seguenti informazioni si riferiscono ai tipi standard sopra elencati. Le varianti che si discostano da queste hanno dati diversi a causa della loro funzione.

Applicazione	Campo di regolazione di temperatura Temperatura di spegnimento ϑ_{off} Temperatura ambiente sul deragliatore Differenziale di commutazione termico Temperatura ambiente durante il deposito e trasporto	0...*...28...85 °C 110 °C (0-9 K) max. 50 °C (T50) 11.0 K \pm 5.5 K -30...+90 °C
Taratura	Tolleranza di taratura Costante di tempo in acqua	\pm 7 K <45 s
Versione	Filetto di collegamento Raccordo in ottone pressato Asta riscaldante rotonda Carico superficiale Collegamento elettrico Pressione Custodia parte superiore Custodia parte inferiore Protezione	R 1 1/2 " conico CuZn40Pb2 Incoloy 825, 2.4858 8-9 W/cm2 Tecnologia di avvitatura max. 10 bar Policarbonato, RAL 7035 (grigio chiaro) Policarbonato, RAL 7016 (grigio antracite) IP41 secondo EN 60529

Nota di montaggio

Il montaggio deve essere orizzontale. Le aste riscaldanti devono essere completamente coperte di liquido. La circolazione del liquido attraverso la resistenza elettrica non deve essere ostacolata.

Nota bene: Questo elemento riscaldante può essere utilizzato sia per serbatoi in acciaio inox che in acciaio nero/smaltato. A seconda del tipo di serbatoio, l'impostazione deve essere selezionata mediante l'interruttore DIP all'interno dell'alloggiamento.

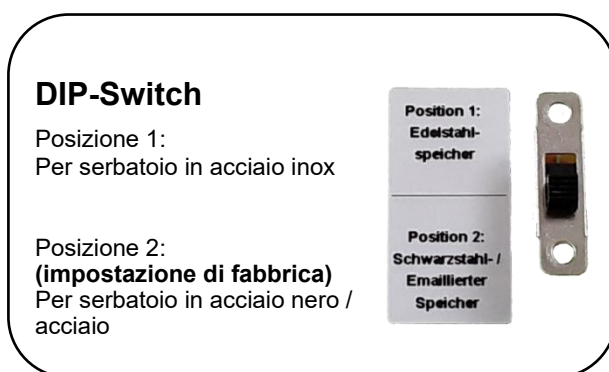

Schema elettrico

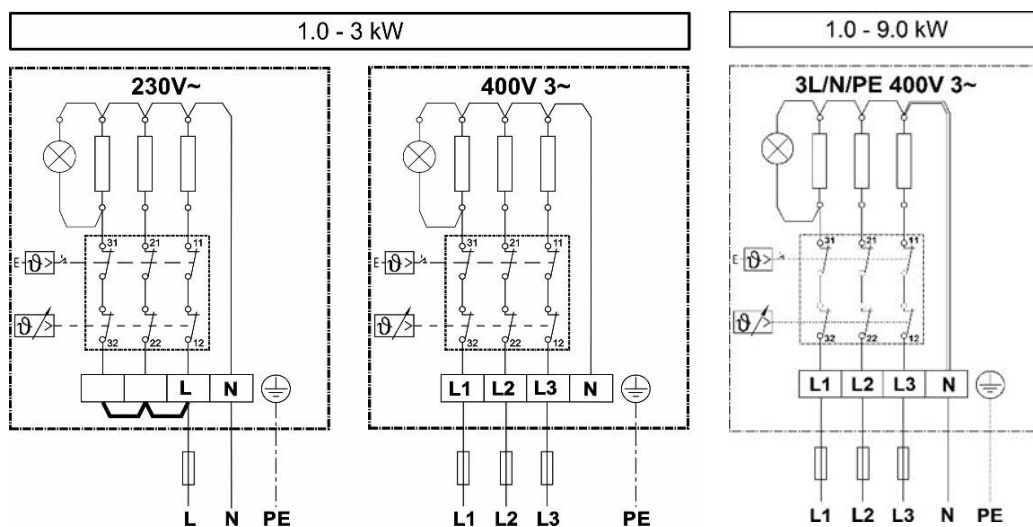

Dimensioni
012-5501 – 012-5507

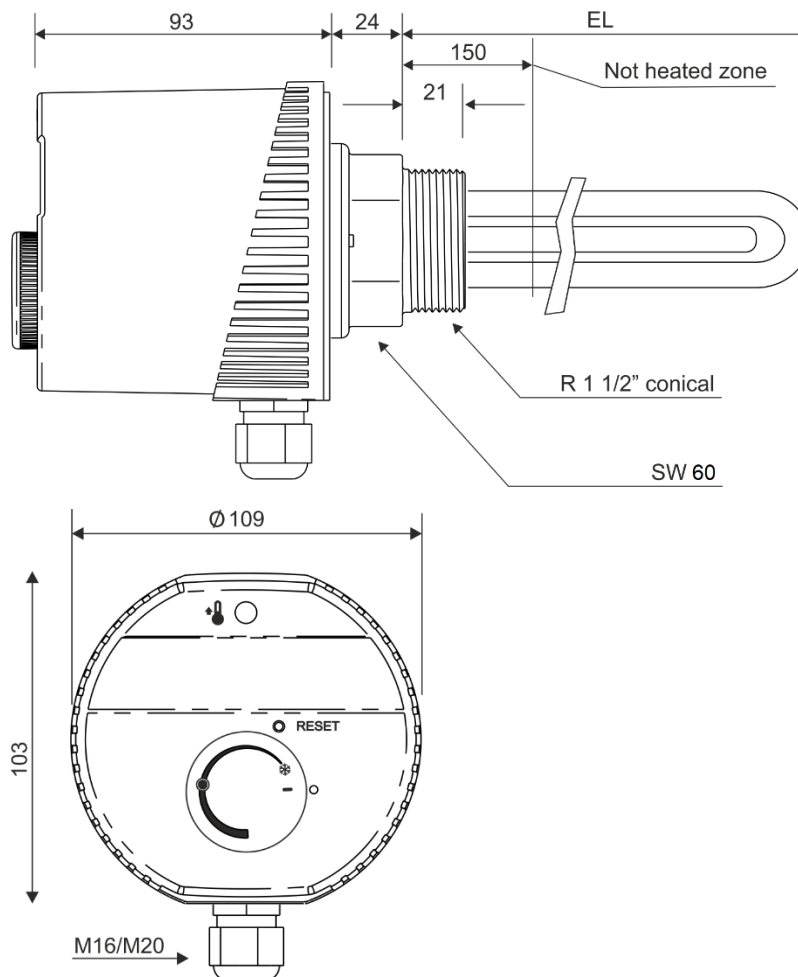

Dimensioni
012-5508 -012-5509

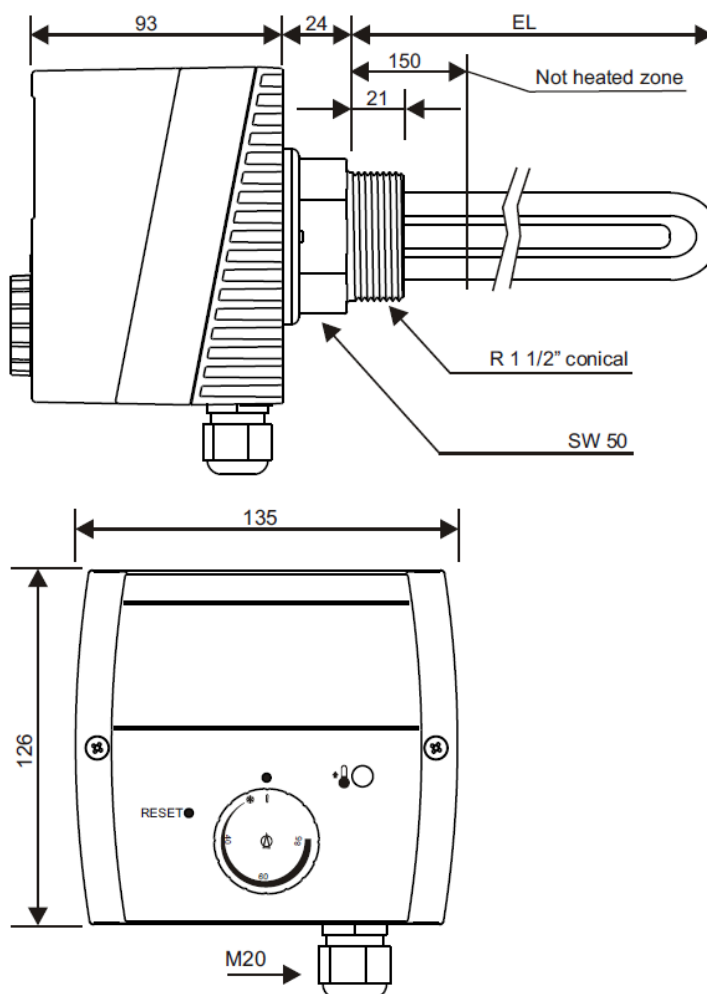

Calefactor eléctrico
montaje aislado

AHIR-BI-OP-...

con combinación de termorregulador / limitador para
el regulador de consumo Fronius OhmpilotAutoconsumo fotovoltaico

- Elementos calefactores para control continuo con:
 - Fronius Ohmpilot hasta 9 kW
 - AC•THOR (my PV)
 - o AC•THOR hasta max. 3 kW
 - o AC•THOR 9s hasta max. 9 kW
 - SolarEdge Home regulador de agua caliente hasta max. 3 kW
- Control de potencia de 0 a 100%



Aplicación

Como calefacción adicional de agua potable y agua de calefacción en sistemas fotovoltaicos. El uso con mezclas de agua y glicol u otros fluidos no es compatible con estas resistencias. Sin embargo, Askoma AG puede ofrecerle otras resistencias adecuadas para este fin.

Características

- RE El calefactor eléctrico consta de tres varillas calefactoras redondas en forma de U, que están montadas en una boquilla de latón 1½" cónica aislada mediante fundas de plástico aptos para alimentos. Gracias al montaje aislado de las varillas calefactoras redondas, los equipos también son adecuados para acumuladores esmaltados. Mediante un interruptor DIP integrado, la resistencia equipotencial puede puentearse para usarse en acumuladores de acero inoxidable. La zona no calefactada es de 150 mm para todas las potencias. Adecuado para el calentamiento diario de agua caliente.
- RT Regulador de temperatura electromecánico según EN 14597, no a prueba de rotura.
- LST Limitador de temperatura electromecánico según EN 14597, a prueba de rotura, cuando se supera la temperatura de desconexión, el mecanismo se desconecta y permanece bloqueado en esta posición. El desbloqueo se realiza manualmente después de que el tubo sensor se haya enfriado aprox. 10 K.
- Constante de tiempo del tubo sensor según EN 14597
 - Modo de funcionamiento TR Tipo 2 B según EN 14597
 - Modo de funcionamiento STB Tipo 2 BK según EN 14597

Resumen de modelos

Agua potable y agua de calefacción
Incoloy 825, 2.4858

Modelo	N.º de pedido	Rendimiento	Longitud de inmersión [L]
AHIR-BI-OP-1.0	012-5501	1.00 kW; 230V~ / 400V 3~	300mm
AHIR-BI-OP-2.0	012-5502	2.00 kW; 230V~ / 400V 3~	300mm
AHIR-BI-OP-2.5	012-5503	2.50 kW; 230V~ / 400V 3~	350mm
AHIR-BI-OP-3.0	012-5504	3.00 kW; 230V~ / 400V 3~	400mm
AHIR-BI-OP-3.8	012-5505	3.80 kW; 400V 3~	450mm
AHIR-BI-OP-4.5	012-5506	4.50 kW; 400V 3~	500mm
AHIR-BI-OP-6.0	012-5507	6.00 kW; 400V 3~	600mm
AHIR-BI-OP-7.5*	012-5508*	7.50 kW; 400V 3~	700mm
AHIR-BI-OP-9.0*	012-5509*	9.00 kW; 400V 3~	750mm

Datos técnicos

Aplicación	Rango de ajuste	0...*...28...85 °C
	Temperatura de desconexión ϑ_{off}	110 °C (0-9 K)
	Temperatura ambiente en el mecanismo	máx. 50 °C (T50)
	Diferencial de conmutación térmica	11.0 K \pm 5.5 K
	Temperatura ambiente durante el almacenamiento y el transporte	-30...+90 °C
Calibración	Tolerancia de calibración	\pm 7 K
	Constante de tiempo en el agua	<45 s
Versión	Rosca de conexión	R 1½ " cónica
	Boquilla de latón prensado	CuZn40Pb2
	Varilla calefactora redonda	Incoloy 825, 2.4858
	Carga superficial	8-9 W/cm ²
	Conexión eléctrica	Tecnología de atornillado
	Presión de trabajo	máx. 10 bar
	Tapa de la carcasa	Polycarbonato, RAL 7035 (gris claro)
	Base de la Carasa	Polycarbonato, RAL 7016 (gris antracita)
	Tipo de protección	IP41 según EN 60529

Nota de montaje

La instalación debe ser horizontal. Las varillas calefactoras deben estar completamente cubiertas de líquido. No debe obstruirse la circulación del líquido a través de la varilla de calentamiento.

Tenga en cuenta lo siguiente: Este elemento calefactor puede utilizarse tanto para tanques de acero inoxidable como para tanques de acero negro / esmaltados. Dependiendo del tipo de tanque, el ajuste debe seleccionarse mediante el interruptor DIP situado en el interior de la carcasa.

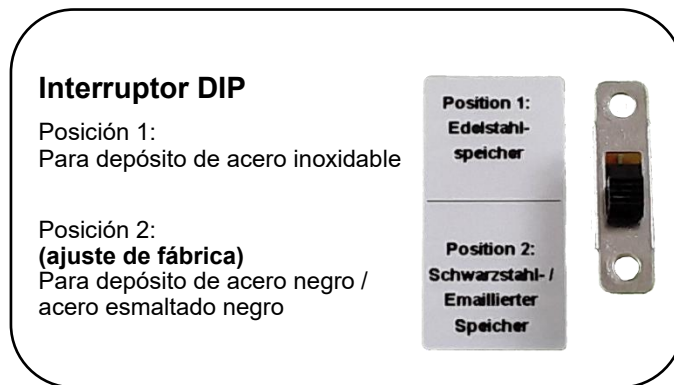

Esquema eléctrico

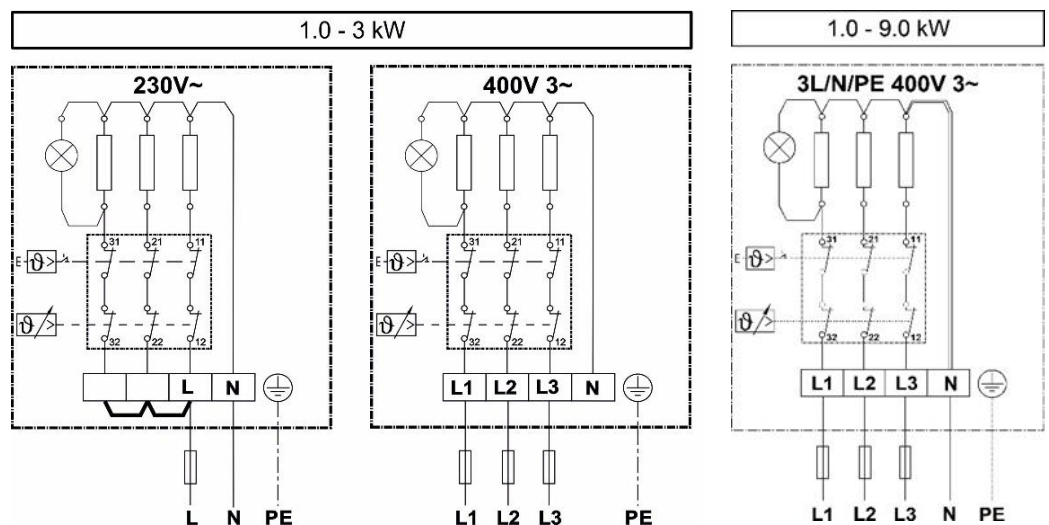

Dimensiones
012-5501 – 012-5507

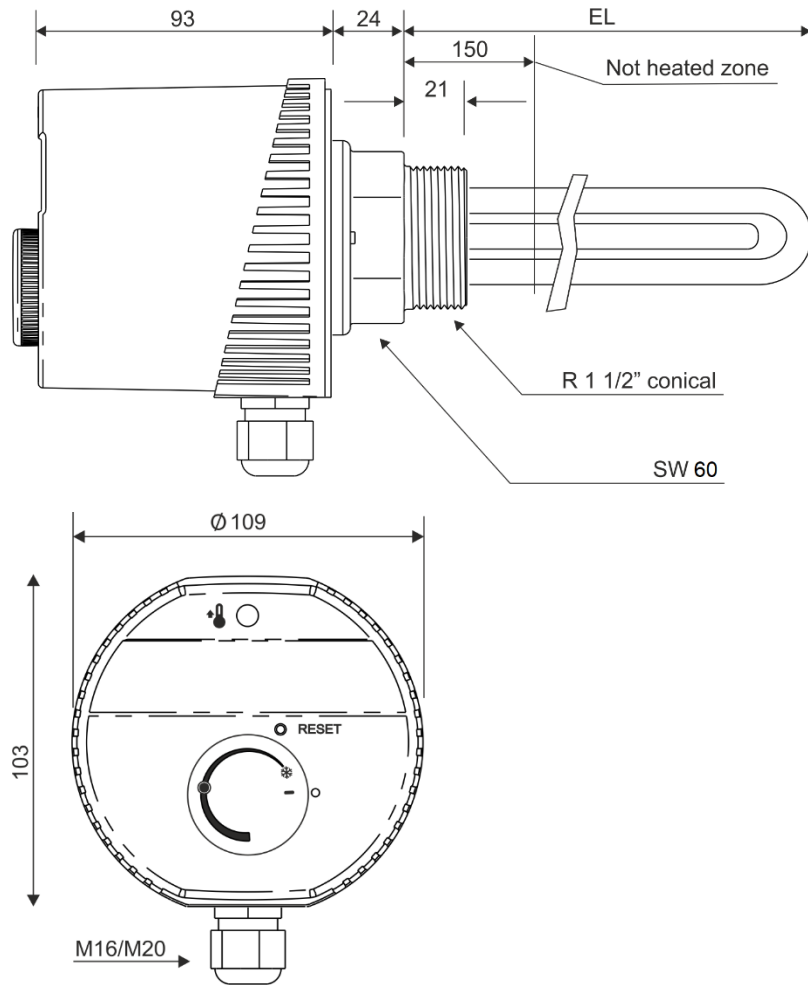

Dimensiones
012-5508 - 012-5509

